

## Feature Operation

store	AutoDial		AutoDial
use		AutoDial	
display	Display	AutoDial	
place a call on hold			
return to a held call			
	Trans		Connect
<b>Handsfree (if configured)</b>			
activate			
switch to handset			
handset to handsfree			
activate			Handsfree LED flashes
Group Listening to handsfree			Handsfree LED is solid
Group Listening to handset			
	Conf		Connect
<b>Last Number Redial</b>			
activate	Rin9A9n		
when notified		Rn9Call	
cancel	Canc1RA		
activate	Forward		Done
cancel	CheckFw	Canc1Fw	
reinstate	Forward	Done	
view number	CheckFw	Exit	
		Pickup	
answer			
return to first call			
log in			
log off		H or VTLF FFC	
<b>Message</b>			

## Applications

		Select	Edit
B	Done	On or Off	
		Select	I
Done		Dial	
		Select	I Done
			Dirctry

## Explanations

	Lift the handset, or press a DN key, or press the Headset key, or press the Handsfree key.
	Replace handset, or press  to end the call.
	Dial number (see "Remarks", below).
or	Press the feature key or line (DN) key located beside the flashing or solid indicator.

### Remarks

<b>A</b>	The name or number can be edited before continuing.
<b>B</b>	Enter or Edit the name you wish to associate with the number, or Enter the text of your Set-to-Set message, using the dial pad (maximum of 24 characters). Press  to select special characters. Press  to insert spaces or move to the next character location (if required).
<b>C</b>	Enter or Edit the number you wish to store (maximum of 31 digits). Include access codes for external or toll calls.
<b>D</b>	You may use the dial pad to enter the first letter of the name you are seeking. (e.g. press  to go the first entry that begins with the letter "B").
<b>E</b>	Enter the Virtual office Terminal LogoN (VTLN) Flexible Feature Code (FFC).
<b>F</b>	Enter your password.
<b>G</b>	Enter the primary line (DN) assigned to your telephone.
<b>H</b>	Enter the Virtual office Terminal LogoF (VTLF) Flexible Feature Code (FFC).
<b>I</b>	Enter the name of the person you want to call. Enter the last name first. Separate the last name and first name with a comma. The comma is the first character on the key. Press the Resume Key to refine your search.

## Call Log and Directory

Callers			Select	New or Old
		or		
Dial A				
	Dirctry	Next A	Done A	
Delete	Yes			
		or		Select DelList
<b>Redial List</b>				
		or	or Redial	
				Select
Dial A				
			Select	AddNew
	B	Next	C	Done
Delete	Yes			
		or	D	Dial A
Edit	B	Next	C	Done
		Select	DelList	Yes
		Select	Select	
			On or Off	Done
		Select		Select
	Enter		Enter	Done

## Introducing your Avaya Digital Deskphone

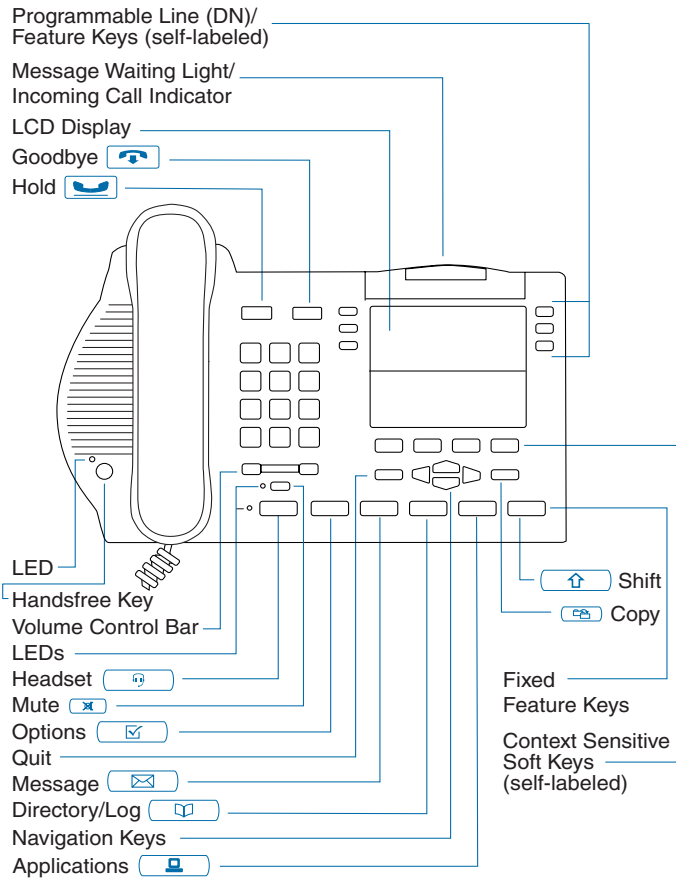

## Programming your Avaya Digital Deskphone

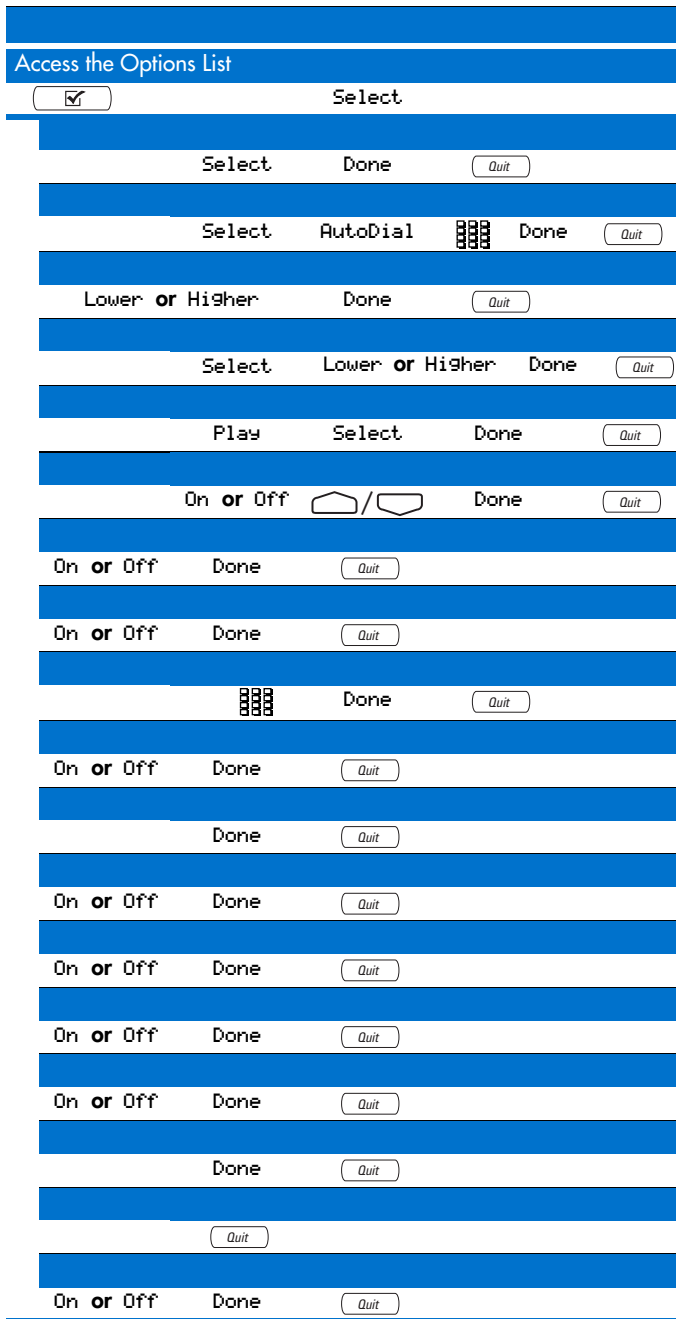

# Avaya Digital Deskphones

## 3903 and 3904 Quick Reference Card



For information on using your Avaya 3903 Digital Deskphone or Avaya 3904 Digital Deskphone when connected to a Meridian SL-100 system, please consult the *Avaya Digital Deskphones 3902, 3903, 3904 Quick Reference Guide*.

For additional information on the operation of your telephone, please consult the *Avaya Digital Deskphones 3901, 3902, 3903, 3904 User Guide*.