

DIP 01-1B	KMC - 1	Phone: -14838
------------------	----------------	----------------------

CONTACT PERSON	building	room	phone	fax	e-mail
M. Gorgoi	14.51	3332	14797	14980	gorgoi@bessy.de
F. Schäfers	14.51	3313	12946	14980	schaefers@bessy.de
M. Mertin	14.51	3354	12930	14980	mertin@bessy.de

OPTICAL LAYOUT (schematic)

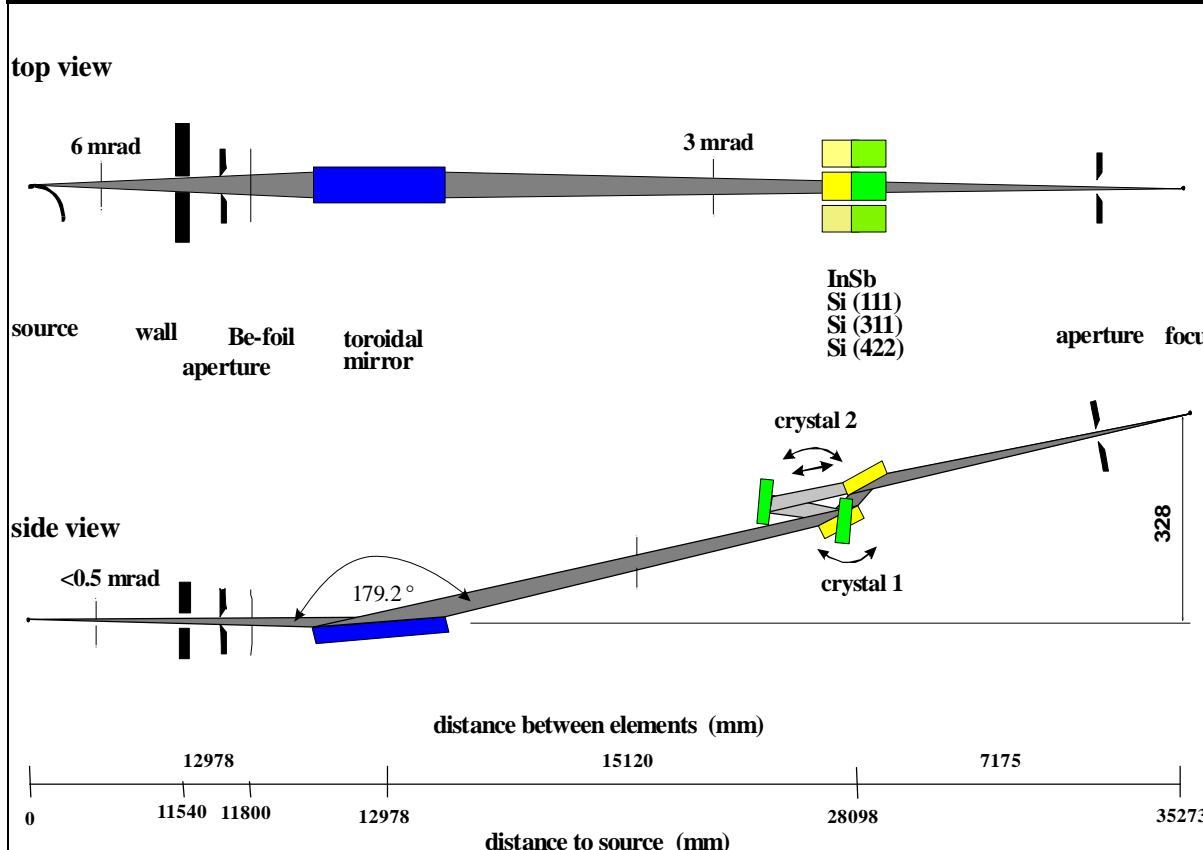

Acceptance	6 mrad (hor) x 0.5 mrad (vert.)
Filter	100µm Be (VIS/UV-filter), water cooled
Focusing optics	toroidal mirror Si/Pt 800 · 130 mm ² , Θ = 0.4°, 1:1.6 mag.
Monochromator	Double-crystal monochromator, angular range 5° - 82° (InSb (111) 1674 - 15000 eV (2d=0.748 nm)) (not installed) Si (111) 1997 - 15000 eV (0.627 nm) Si (311) 3817 - 15000 eV (0.328 nm) Si (422) 5639 - 15000 eV (0.222 nm)
Diagnostics	Ionisation chamber for MOSTAB intensity control and feedback Au-, Cu mesh (I-o monitor) Au-photocathode, GaAsP diodes, Si AXUV 100 (2x2, 4x4, 10x10 mm ²) Si 111, 100 diodes (backscattering) for energy resolution / calibration Hor. /vert. slits 0-2 mm, pinholes 0.14 - 2.5 mm ² Filters (high orders, energy cal.): Al,Ti,V,Fe,Co,Ni,Cu,Mo,Ag (1-5 µm) Transmissive Si-PSD for horizontal beam positioning and stabilisation
Experiments	HIKE (High kinetic energy high resolution) PES, NEXAFS, XANES, EXAFS, RFA, Reflection, absorption, diffraction, scattering, transmission Differential pumping stage to experiment (2.5 µm polyimid)
Exp. equipment	Double ionisation chamber (25 µm Kapton) for low vacuum or He-exp.
Reference	F. Schäfers, M. Mertin, M. Gorgoi, <i>KMC-1: a High Resolution and High Flux Soft x-Ray Beamline at BESSY</i> , Rev. Sci. Instrum. 78 , 123102-1-14 (2007)

PERFORMANCE DATA

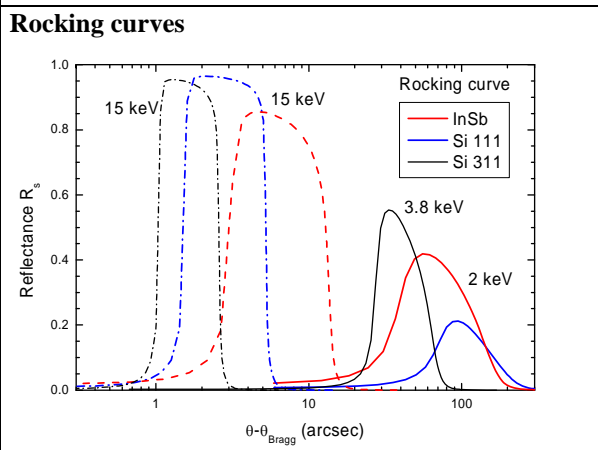
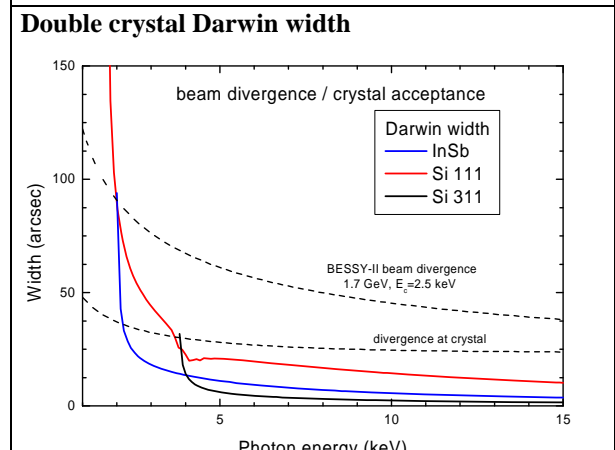
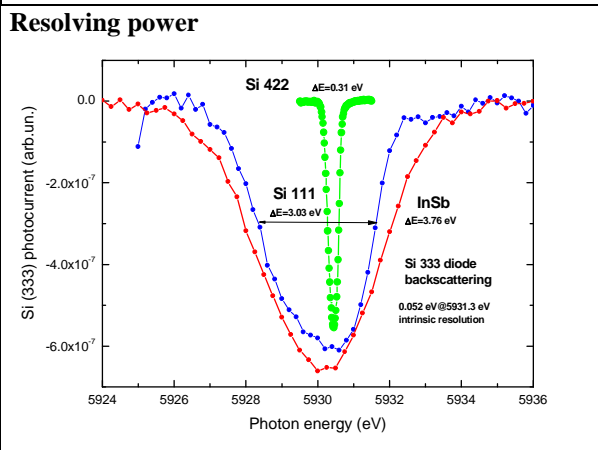
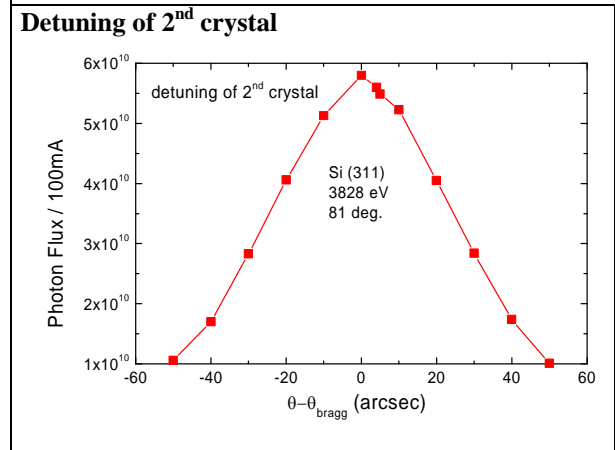
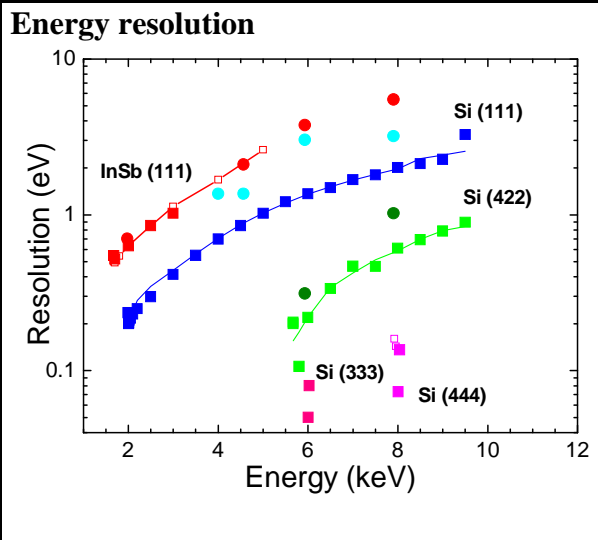
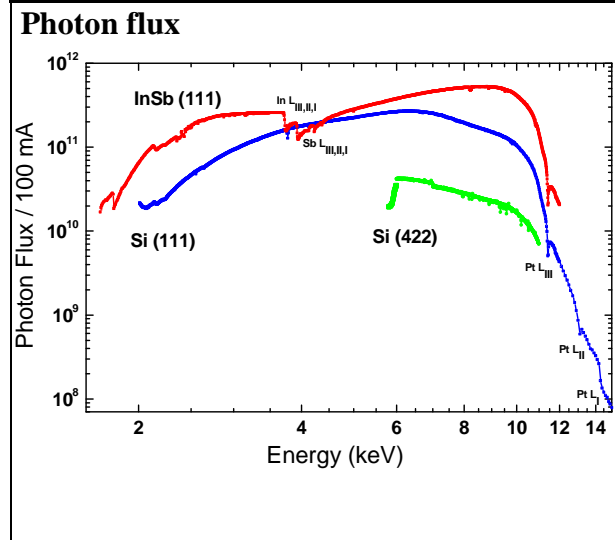

Spot size at experiment:

0.4 x 0.6 mm² (h. x v.)

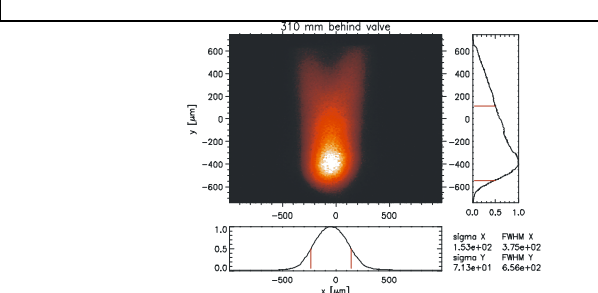

Divergence at focus position:

3 x 0.2 mrad² (h. x v.) FWHM

I₀ - DIAGNOSTIC SECTION

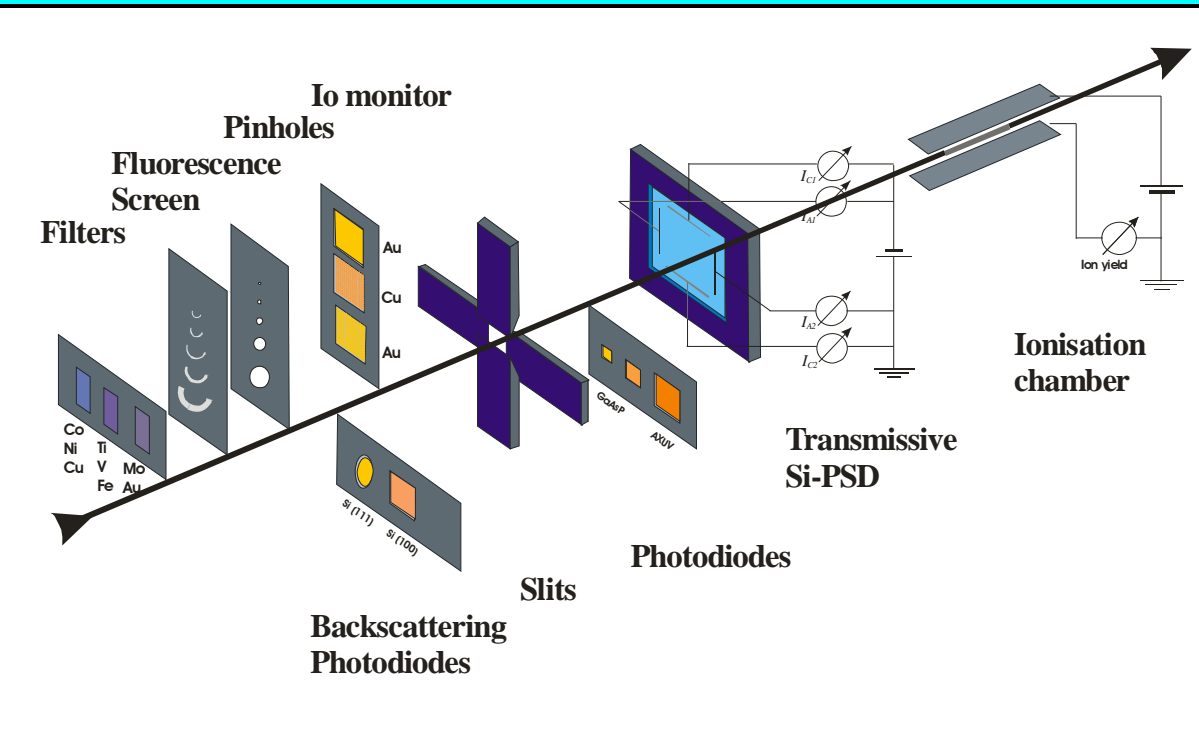

TECHNICAL REFERENCE

FLOOR PLAN

top view

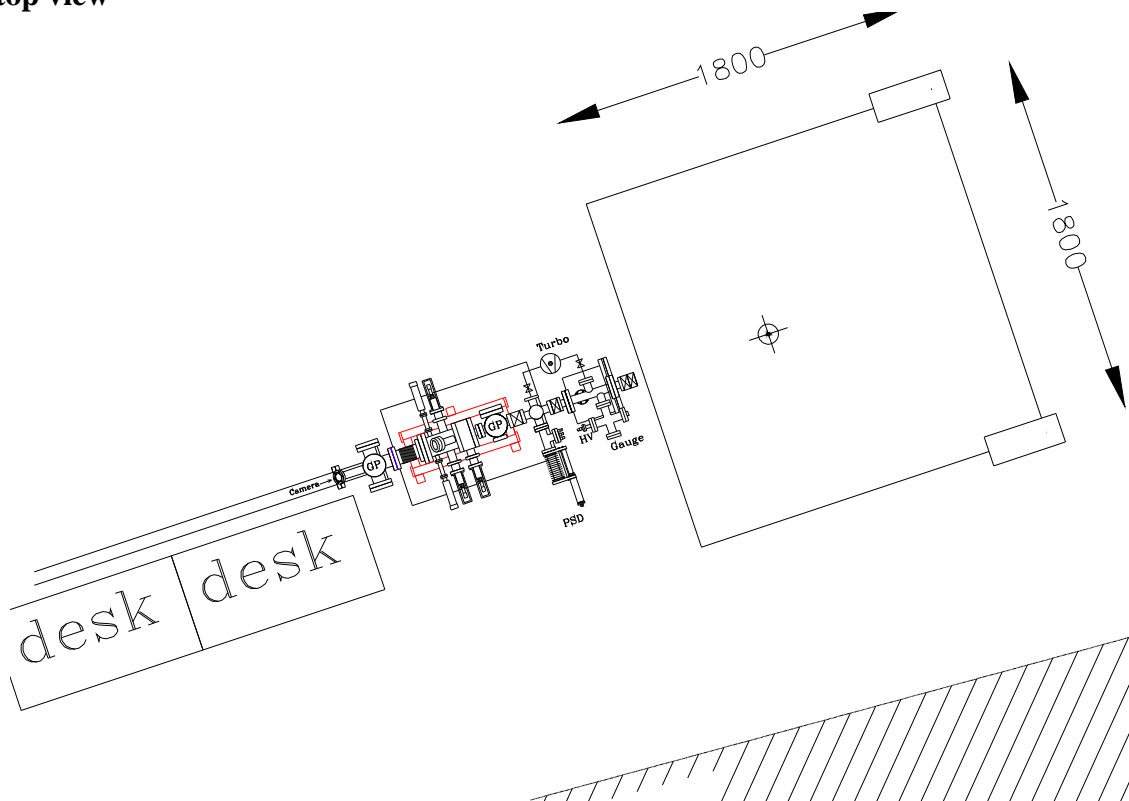

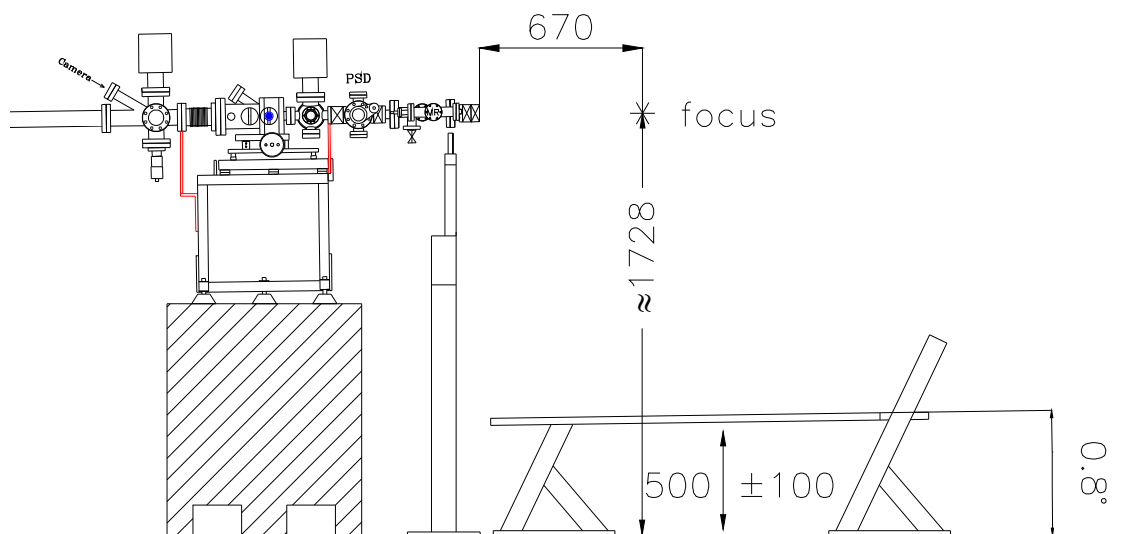
side view**GEOMETRICAL BOUNDARY CONDITIONS**

Experimental area	Platform 1.8 m x 1.8 m Height 500 mm +/-100 mm above floor
Last valve	DN 35 CF double valve with polyimid foil
Focus position	670 mm behind last valve
Focus height above floor	1728 mm
Beam orientation	parallel to platform (+0.8° upwards with respect to floor)

VACUUM REQUIREMENTS

Max. pressure	$<5 \times 10^{-7}$ mbar at last valve, live zero point signal for interlock
Oil free vacuum system	yes

INFRASTRUCTURE AT EXPERIMENTAL STATION

Electrical power supplies	220V, 380 V max 44 kVA
Demineralized cooling water	closed system, forerun 30° / 10 bar, return run *42° / 2 bar
Pressurized air	8 bar
Oilfree exhaust line	available
Exhaust line f. poisonous gases	available
He-recycling system	available
Computer network	available

DATA ACQUISITION

Control system	PC-based monochromator controlsystem
Data-acquisition computer	Personal Computer, measurement bus-extended, OS/2-operating system
Data-acquisition software	EMP II
Remote-control	V24-serial port, AMC-protocol