

PAPER • OPEN ACCESS

First result from the magic-PASTIS using large ^3He SEOP-polarized GE180 doughnut cell

To cite this article: Zahir Salhi *et al* 2016 *J. Phys.: Conf. Ser.* **711** 012013

View the [article online](#) for updates and enhancements.

You may also like

- [Development of a Spin-Exchange Optical Pumping-Based Polarized \$^3\text{He}\$ System at the China Spallation Neutron Source \(CSNS\)](#)
Chuyi Huang, , Junpei Zhang *et al.*
- [A compact SEOP \$^3\text{He}\$ neutron spin filter with AFP NMR](#)
Takashi Ino, Yasushi Arimoto, Hirohiko M Shimizu *et al.*
- [\$^3\text{He}\$ spin filter based polarized neutron capability at the NIST Center for Neutron Research](#)
W C Chen, T R Gentile, R Erwin *et al.*



The Electrochemical Society
Advancing solid state & electrochemical science & technology



249th
ECS Meeting
May 24-28, 2026
Seattle, WA, US
Washington State
Convention Center

Spotlight Your Science

**Submission deadline:
December 5, 2025**

SUBMIT YOUR ABSTRACT

First result from the magic-PASTIS using large ^3He SEOP-polarized GE180 doughnut cell

Zahir SALHI¹, Earl BABCOCK¹, Ramil GAINOV^{2,3}, Klaus BUSSMANN⁴, Hans KAEMMERLING⁴, Patrick PISTEL⁴, Margarita RUSSINA², Alexander IOFFE¹

E-mail: z.salhi@fz-juelich.de

¹Jülich Centre for Neutron Science; Forschungszentrum Jülich GmbH outstation at MLZ Lichtenbergstrasse 1 85747 Garching Germany.

²Helmholtz-Zentrum Berlin für Materialien und Energie GmbH, 14109 Berlin, Hahn-Meitner Platz 1, Germany.

³Kazan Federal University, 420008 Kazan, Russia

⁴Forschungszentrum Jülich GmbH, ZEA-1 Wilhelm-Johnen-Sträße 52425 Jülich Germany.

Abstract. We report on the first results of the newly proposed and prototyped PASTIS coil set, enabling for XYZ polarization analysis on the future thermal time-of flight spectrometers. Our setup uses a wide-angle banana shaped ^3He Neutron Spin Filter cell (NSF) to cover a large range of scattering solid angle. The design assures relative magnetic field gradients $< 10^{-3} \text{ cm}^{-1}$ and large solid angle areas not interrupted by either coils or supports. In the vertical direction nearly 40° are open and the blind spots in the horizontal scattering plane comprise only 3° in 180° due to the square X and Y compensation coils. We present the first results of the field mapping and relaxations time measurements using a large ^3He SEOP polarized GE180 doughnut cell.

1. Introduction

Polarization analysis, PA, of polarized neutrons is a powerful tool for separation of nuclear spin-incoherent background, analysis of complex magnetic structures and the study of magnetic excitations [1]. Several wide-angle spectrometers with PA exist or are under construction [2 -5]. The PA can be performed in a variety of ways depending on the instrument's parameters, however with performance limited by the analyzer height and, in some instances, integration over the height of the detectors or loss of resolution in the vertical direction due to the nature of a supermirror style analyser arrays. Installation of a new longer, height-position sensitive detector bank gives a unique opportunity to prototype and test. A polarized ^3He XYZ analysis system would be able to utilize the full height and position resolution of large area position sensitive detectors and enable analysis at higher neutron energies (energy transfer) than currently available [5 - 7].

For polarized ^3He -based systems, a sufficiently low magnetic field gradient must be maintained over the volume of the neutron spin filter cell in order to obtain ^3He polarization lifetimes of a practical and useful level. Further for any method to obtain information on the Q_\perp and Q_\parallel of the momentum transfer vector Q



over a large solid angle detector, the sample field must be switchable between three orthogonal X-Y-Z directions [9]. Due to practical constraints concerning the amount of polarized ^3He that can be provided, a so-called PASTIS (**P**olarization **A**nalySis on **T**hermal **I**nelastic **S**pectrometer) concept was developed [8], where the ^3He analyser cell shares the magnetic field of the sample. Since the cell occupies the same field volume as the sample, the direction of a large-volume highly uniformed ^3He holding field used to maintain long ^3He NSF lifetimes, must also be changeable between the X, Y and Z directions. Moreover, the ^3He polarization must rotate adiabatically when switching field directions, and the neutron polarization must be adiabatically preserved regardless of field direction. To achieve this, two clear options exist: a magnetized mu-metal geometry, similar to [8], or a resistive coil set similar to [6]. We use a geometry based on magnetized mu-metal. However in our proposed designs certain key differences exist, which build on the experiences from prior devices.

We present an initial design study with finite element magnetic field (FEM) calculations of possible XYZ field configurations suitable for polarized ^3He and adapted to the instrument geometry. Starting with the ideal geometry from the FEM model, the new setup was prototyped and tested after being optimized experimentally for current values and optimal positioning of the coils.

2. Influence of the magnetic field inhomogeneity on the polarized gas

The motivation of this work is the need for XYZ magnetic cavity, which provides a highly homogeneous magnetic field since the magnetic field gradients contribute strongly to the total relaxation of polarized ^3He gas [11-17]. In the presence of such gradients, a moving atom will experience different magnetic field strengths. If the variations of field are close to the transition frequency between Zeeman energy level for the diffusing atom, then spin flip can be induced causing a loss of magnetization. T_{Grad} (gradient relaxation time) is the relaxation time due to the diffusion of ^3He through magnetic field gradient and given by [15]:

$$1/T_{1Grad}[\text{h}] = \frac{7000}{P[\text{bar}]} \left(\left(\frac{\Delta B_x}{B} \right)^2 + \left(\frac{\Delta B_y}{B} \right)^2 \right) \quad (1)$$

Here p is the gas pressure in bar, ΔB_x and ΔB_y are the orthogonal gradients of the static holding field B . The influence of the magnetic field gradient on the total relaxation time for different pressures is shown in figure 1.

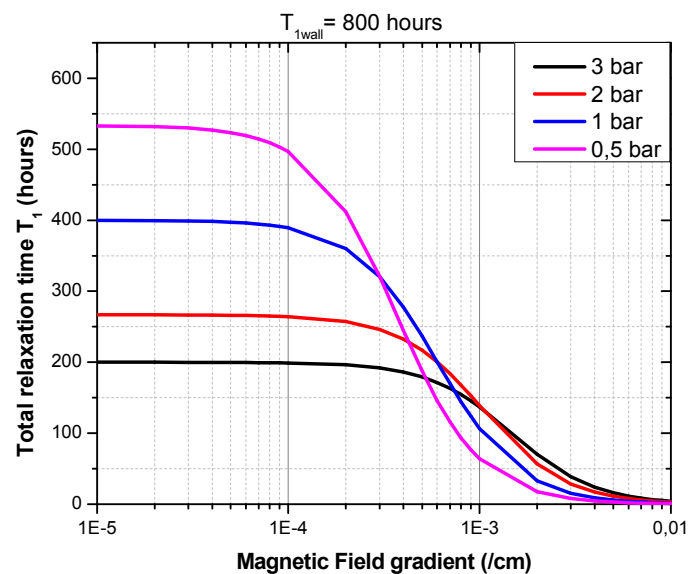

Figure1. Influence of the field gradient and gas pressure on the total relaxation time of polarized gas.

From Figure 1, we can see clearly that the total relaxation time suffers strongly from the inhomogeneity of the magnetic field and is more sensitive to the field gradient at low pressure. For the 0.5bar pressure the observed saturation is about $8 \times 10^{-5} \text{ cm}^{-1}$, whereas a significant decrease of the relaxation time at 3bar can be observed only for gradients larger than 10^{-3} cm^{-1} . Therefore, for the test of our setup we use a large cell with the pressure of 0.5bar in order to be more sensitive to the field gradient. For the final test with thermal neutrons, we will use a cell with an opacity of about 30 ($10\text{cm} \times 3\text{bar} \times 1\text{A}$) [25] to lower the influence of the gradient on the total relaxation time. Going to this higher pressure not only reduces the field homogeneity requirements, but also scales down the overall size of the cell for the thermal beam. This is important for two reasons: first, the total optical pumping efficiency is strongly related to the total volume of alkali-metal vapour that must be polarized, so that going to a smaller higher pressure cell, will in general reduce the amount of light required to polarize each ^3He atom, because the alkali-alkali relaxation mechanism tend to be dominate over alkali- ^3He for our cell parameters. Second, the smaller cell will require a correspondingly smaller homogeneous magnetic field region, allowing this device to be more compact and suitable to the typical constraints on a neutron instrument.

3. Magnetic system design and prototype

A large step has been made in the design of wide-angle polarization analysis. The primarily PASTIS system developed at the ILL[8], uses a set of X, Y and Z coils to create a homogeneous magnetic field in three orthogonal directions in a compact format, which was suitable to known neutron instrumentation and had acceptable ^3He relaxation times. This device was further refined to reduce the dead angles [5]; however dead angles remain still the main limitation.

Our so-called Magic-PASTIS design [18] is based on a nearly open mu-metal geometry. The conceptual design was then adjusted and optimized using finite element calculations performed with commercially available software [19]. Some results of these calculations are shown in Figure 2. The present coil layout consists of a pair of compensated Helmholtz coils coupled to horizontal mu-metal sheets, which work as a kind of magnetic capacitor and generate a field in the Z direction. Two further pairs of rectangular coils (together with current sheets, realized by two orthogonal coils wound upon the mu-metal sheets, and magnetized iron-core solenoid rods) are used to generate a homogeneous field along X and Y directions.

We aim to produce an improved homogeneous magnetic field in a large region by introducing mu-metal sheets while reducing the blind areas due to the coil frames of the more conventional compensated square/circular coils of the resistive coil PASTIS systems [6,8]. Those systems, for example, have eight vertical dead areas (in the horizontal plane) of approximately 5° or more at $\pm 18^\circ$; $\pm 71^\circ$ and $\pm 109^\circ$ whereas the design presented in this article has more than 40° opening in the vertical plane and only four small 3° dead angles, one every 90° , in the horizontal plane. These dead angles can be rotated arbitrarily with respect to the incident beam for either system. The centre of the configuration is the sample installed in a magnet or a cryostat, thus placing the ^3He cell itself significantly off-centre. A picture of the completed prototype is shown in Figure 3.

Another feature of our approach is that we have also fully modelled the neutron guide field configuration. Typically on PASTIS systems the in-plane X and Y directions provide relatively good neutron spin transport to the sample and through the ^3He NSF cell; however the vertical, i.e. transverse to the neutron beam, Z-direction proves to be more difficult as crossing through the side of a Helmholtz pair give a low field area for the neutron path. A guide field should then be added to this region, but this causes often to increase of ^3He relaxation rates because of the proximity to the cell. Therefore we have fully modelled the guide fields in conjunction with the magic-PASTIS system to insure that the polarization of both the neutrons and the ^3He will be properly preserved. A discussion of the guide field concept has been given in [10].

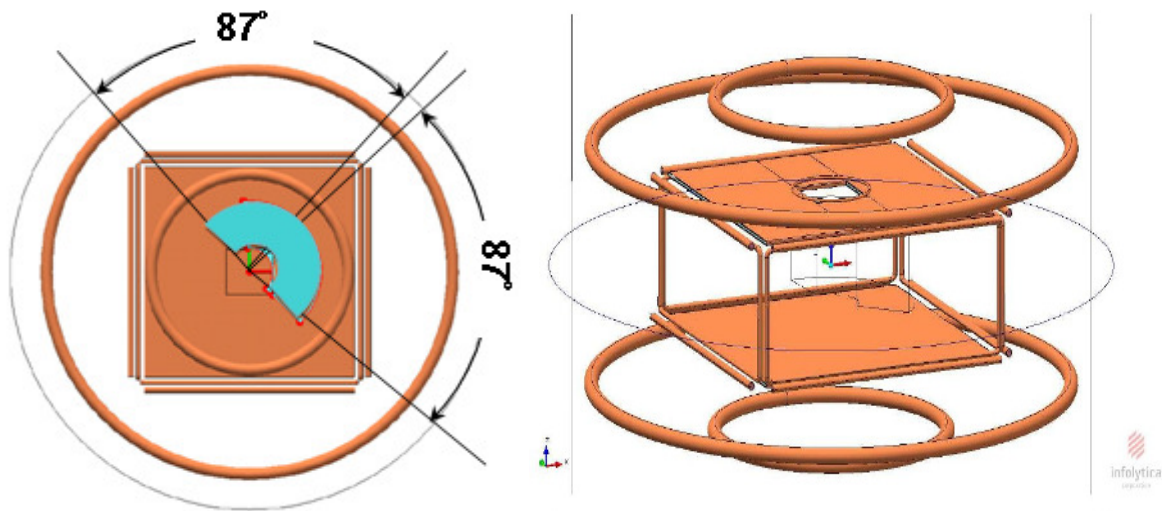

Figure 2. Coil layout for the PASTIS concept. Left: top view of the setup showing the cell position and the 3° dead angle. Right: a side view of the setup showing the opening for the cryostat and the cell position. Helmholtz coils (70cm), horizontal mu-metal sheets (35cm*35cm)

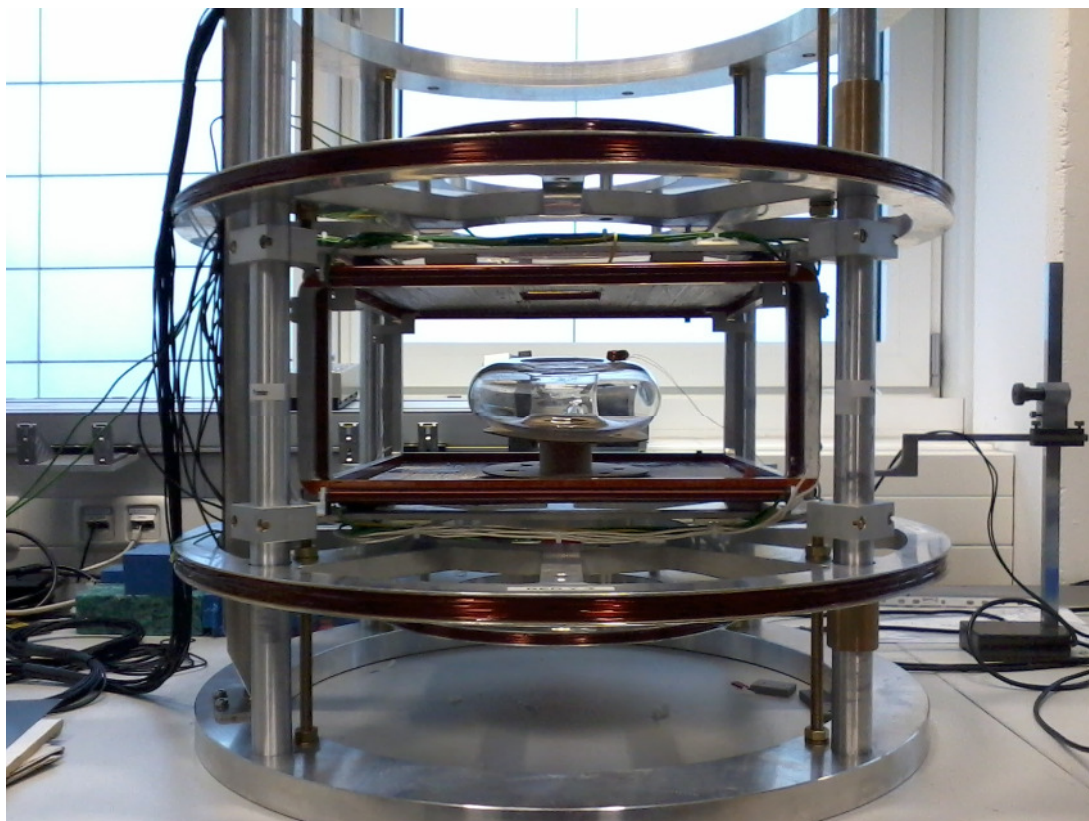

Figure 3. The magic-PASTIS prototype. Inside one can see a large doughnut-shaped ^3He cell (with NMR coils on the top of it) used for measurements of ^3He relaxation time.

4. Field mapping results

The magnetic field inside of Magic-PASTIS has been measured to optimize the homogeneity of the magnetic field in our set of coils. This has been done at different positions along the magnetic field axis using a Hall probe magnetometer Model 7030 manufactured by F.W. Bell [20], which has the sensitivity of 10nT. The computed currents obtained using the FEM calculations have been served as starting values. After that the field was measured at different ratios of electrical currents until the best field homogeneity was achieved.

Figure 4a shows FEM calculations of the magnetic field in the x, y direction. It is obvious that the inner part is highly homogeneous, including also the position of the ^3He cell. As seen from Fig. 2, the coil setup fulfils this condition for a large area, allowing the polarization analysis in a wide angular range. Figure 4b shows an example of the field map along the x, y direction achieved for the optimal current values. The measured magnitudes of magnetic fields are in good agreement with calculations. The values optimised here are used later for the measurement of the relaxation time (see section 5).

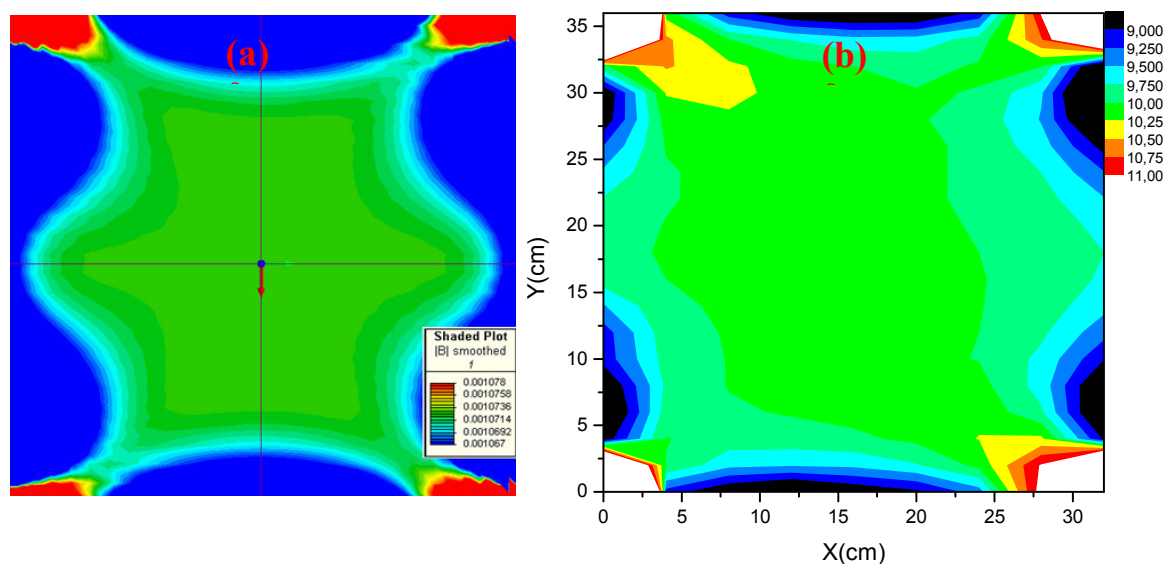

Figure 4.(a) FEM calculation for the X, Y directions,(b) magnetic field mapping along X, Y directions measured using Hall probe magnetometer.

5. Procedure for relaxation time measurement and results

Figure 5a shows the picture of a very large, $D = 22$ cm, doughnut-shaped cell called Homer. The cell was prepared with Rb/K mixture and 0.5 bar of ^3He [21,22]. This cell is made purely only for testing of ^3He relaxation times in the new magic-PASTIS coil system shown earlier in Figure.1: the low ^3He pressure makes the cell very sensitive to magnetic field gradient relaxation and, as result, is a good probe to optimize the performance of the magic PASTIS magnetic cavity.

Aided by the low ^3He pressure, good glass and cell preparation techniques, Homer demonstrates 1050 hours of total relaxation time in what we presume to be an “ideal” magnetic holding field (Figure 5b). Regardless of the true lifetime of Homer in an actually “ideal” holding field and considering corrections for all losses from the NMR FID measurements of the lifetime, such a measured lifetime insures that with our NMR detection system, the measured lifetimes of Homer inside the magic-PASTIS system will be entirely dominated by the magnetic field gradients with only small corrections that we can neglect for the purpose of this work to optimise the field configuration.

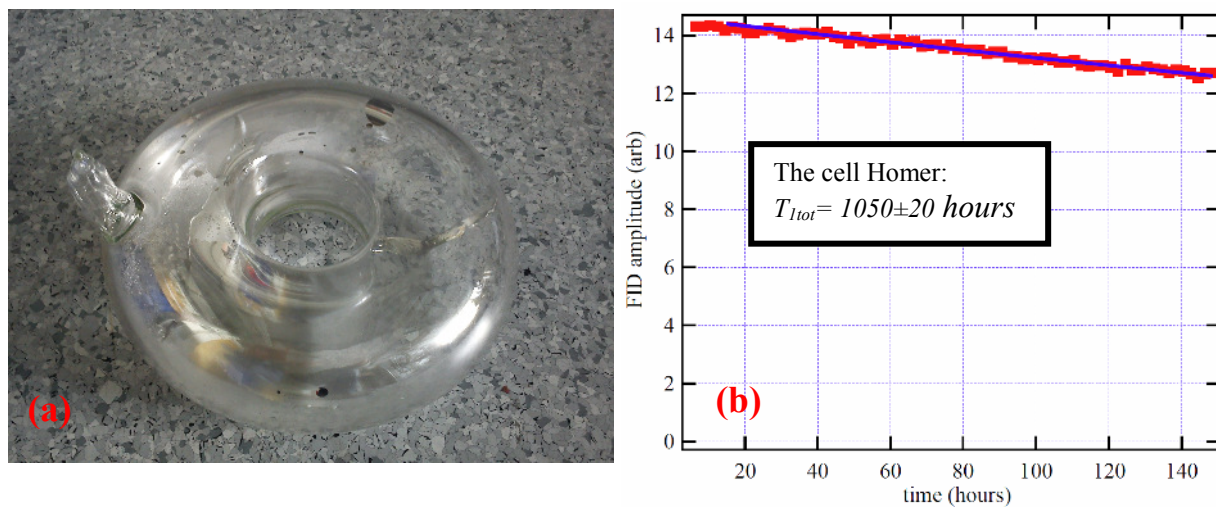

Figure 5.(a)First in the world doughnut shaped cell called Homer. The cell is filled with 0.5 bar of ^3He to make it sensitive to magnetic field gradients. (b)FID NMR exponential fit allowing for the determination of the relaxation time $T_1 = (1050 \pm 20)$ hours;

The build-up and decay of the relative polarization was monitored using the NMR free induction decay (FID) [11-17]. The FID of the longitudinal magnetization was periodically monitored, typically every hour: ^3He polarization is proportional to the amplitude of the FID signal. The exponential decay fit of the amplitude-time dependence gives a value of T_1 ; for a long T_1 a reliable measurement typically takes several days.

The ^3He doughnut-shaped cell was polarized using the SEOP technique [23]. For this purpose the cell is placed in a long solenoid, providing the magnetic field of about 10G at the centre and the field homogeneity better than 1mG/cm along the axis at the centre of the solenoid coil. The cell is heated to achieve a suitable alkali metal density and illuminated by a circularly polarized light from a high power laser spectrally narrowed by the chirped volume Bragg grating (VBG). In order to cover the cell with polarized light the cell was illuminated from both sides: each laser covers the half of the cell. A large oven was built specially to host such large cell.

After reaching a reasonable polarization, the cell was transported in the permanently magnetised box with long gradient relaxation time [24], and, finally, placed in the centre of the Magic-PASTIS system as shown in Figure 3.

The results of the NMR FID measurements and the exponential fits allowing for the determination of the relaxation time T_1 are presented in Figures 6 and 7. Figure 6 shows ^3He lifetime measurements with Homer before and after optimization of correction coil currents for X direction. We point out here that $T_1=70$ hours obtained at 0.5bar using the testing cell corresponds to $T_{1\text{grad}}=450$ hours of magnetic lifetime and total $T_{1\text{tot}}=165$ hours for the case of a working pressure of 3bar. These results have been well reproduced by several measurements.

The same procedure has been also repeated for other two directions: Y and Z. The results are summarized in Figure 7. The obtained values of T_1 for X and Z directions are about 70h (450h at 3bar). Unexpectedly, the T_1 obtained for Y direction was only 35h in contrast to $T_1=70$ h obtained for X direction. Regarding the symmetry of the x-y coils geometry, this can be explained by the fact that optimal currents values of the compensations coils for X direction are not appropriate for those of Y direction because of a small mechanical asymmetry or winding inaccuracy. More efforts could be done to obtain the appropriate optimal current ratios using field mapping and optimization. However, even the achieved relaxation time of $T_1=35$ h at 0.5bar corresponds to $T_{1\text{grad}}=220$ h and $T_{1\text{tot}}=120$ h at 3bar, which is satisfactory for our

applications. This value is still better than our aim to achieve the total relaxation time of 100h because of an important reason: to refill the cell by polarized ^3He gas not often than one time per day.

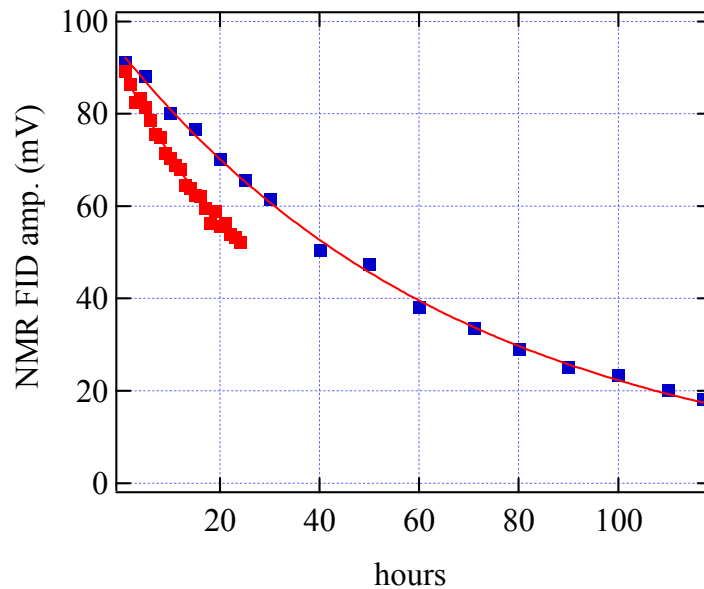

Figure 6. Results of ^3He lifetime measurements with Homer before (Red) and after (Blue) the optimization of correction coil currents for X direction. $T_1 = 70$ hours obtained at 0.5bar corresponds to $T_{1\text{grad}} = 450$ hours of magnetic lifetime and total $T_{1\text{tot}} = 165$ hours at 3bar.

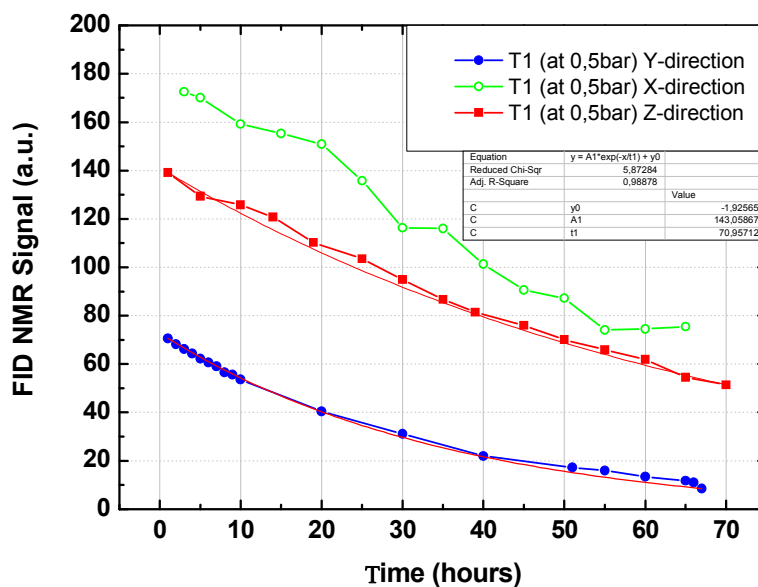

Figure 7. Results of ^3He lifetime measurements after the optimization of the correction coil currents for all three directions.

It is necessary that the field gradient is kept below 10^{-3}cm^{-1} over the volume of a large neutron spin filter cell in order to make the depolarization of the polarized ^3He sufficiently low. This level would keep the cells in the instrument during a long time, which is enough to make experiments feasible by reducing the time spent refilling, calibrating and transporting polarized cells/gas to the beamline to once per day or less. For our setup the gradient relaxation time was measured to be 450 h, corresponding to volume averaged field gradient of $8 \times 10^{-4}\text{cm}^{-1}$, which will allow us to work with the polarized cell without refilling for more than 24h with a good performance.

4. Conclusions

We have designed, prototyped, and tested the magic-PASTIS XYZ magnetic cavity. The design assures relative field gradients $<10^{-3}\text{cm}^{-1}$ and large solid angle areas, which are not interrupted by either coils or supports. In vertical direction nearly $\pm 20^\circ$ are open and the blind spots in the horizontal scattering plane comprise only 3° due to the square compensations coils for X and Y directions. The magic-PASTIS magnetic cavity prototype has been tested for ^3He lifetime, and a 70 hour lifetime at 0.5bar was achieved which corresponds to the 450 hour magnetic lifetime or the 165 hour total lifetime for a 3bar cell when including the ^3He dipole-dipole self-relaxation to the magnetic field gradient relaxation.

Work is steadily progressing towards the realization of optimized GE180 banana cells, the PASTIS control system and the guide fields for polarized neutrons. Once the critical mass of components is available we will proceed with neutron sample measurements, data collection and analysis techniques.

6.1. Acknowledgments

We acknowledge support from the BMBF through the collaborative project 05E10CJ1 of the ESS design update work package K3 and the project 05K12CB1 supported the cooperation between JCNS and HZB. This research project has been also supported by the European Commission under the 7th Framework Programme through the 'Research Infrastructures' action of the 'Capacities' Programme, NMI3-II Grant number 283883. The authors want to thank A. Schwaitzer (from the JCNS glass workshop) for his help and advices concerning cell fabrication.

References

- [1] Moon R M, Riste T, Koehler W C., 1969 *Phys. Rev.* 181 920.
- [2] Stewart J R, Deen P P, Andersen K H *et al.*, 2009 *J. of Appl. Crystal.* 42 69-84
- [3] Schweika W, Boni P., 2001 *Physica B* 297 155
- [4] Voigt J, Babcock E, Brueckel Th., *J. of Phys. Conf. Series* 211 012032
- [5] Beecham C J, Boag S, Frost C D *et al.*, 2011 *Physica B- Condensed Matter* 406 2429-32
- [6] Andersen K H, Jullien D, Petoukhov A K, Mouveau P, Bordenave F, Thomas F, Babcock E., 2008 *Physica B-condensed matter* 404 2652-4
- [7] Babcock E, and Ioffe A., 2011 *Journal of Phys. Conf. Series* 294 01 2005
- [8] Stewart J R, Andersen K H, Babcock E, *et al.* 2006 *Physica B-condensed matter* 385-86 11425
- [9] Scharpf O, and Capellmann H., 1993 *Physica Status Solidi A - App. Res.* 135 359-79
- [10] Voigt J, Soltner H, Babcock E, Aldus R J, Salhi Z, Gainov R R, Brückel T., *QENS/WINS2014, May 2014 Autrans France*
- [11] Newbury N R, Barton A S, Cates G D, Happer W, Middleton H., *Phys. Rev. A*, 48(6), 1993. doi:10.1103
- [12] Cates G D, Schaefer S R, Happer W., *Phys. Rev. A*, 37, 1988.
- [13] Cates G. D, White D J, Chien T, Schaefer S R, Happer W., *Phys. Rev. A*, 38, 1988.
- [14] Jacob R, Teter J, Saam B, Chen W, Gentile T., *Physical Review A*, vol. 69 2004.
- [15] Schmiedeskamp J, Heil W, Otten E, Kremer R, Simon A, Zimmer J., *The European Physical Journal D*, 2006
- [16] Jacob R E, Morgan S, Saam B, Leawoods J C, *Physical Review Letters*, vol. 87, p. 143004, October 2001.
- [17] Babcock E D., *PhD Thesis, University of Winsconsin-Madison (2005)*
- [18] Babcock E, Salhi Z, Pistel P, Simeoni G, Ioffe A., *Journal of Physics: Conference Series* 528(2014) 01201
- [19] MagNet 2D/3D Electromagnetic Field Simulation Software, *Infolytica Co. Montral, Qubec H2X 4B3 Canada*, <http://www.infolytica.com/en/products/magnet/>
- [20] <http://fwbell.com/products/gauss-meters.aspx>
- [21] Salhi Z, Babcock E, Pistel P, Ioffe A., *Journal of Physics Conference Series* 07/2014; 528(1):012015.

- [22] Chen W C, Gentile T R, Fu C B, Watson S, Jones G L, McIver J Wand Rich D R, *Journal of Physics: Conference Series* 294(2011)12003
- [23] Walker T, Happer W., *Rev Mod Phys*, vol. 69, no. 2, pp. 629–42, 1997.
- [24] Petoukhov A K, Guillard V, Andersen K H, Bourgeat-Lami E, Chung R, Humblot H, Jullien D, Lelievre-Berna E, Soldner T, Tasset F, Thomas M., *Nuclear Instruments and Methods in Physics Research A* 560 (2006) 480–484
- [25] Petoukhov A K, Andersen K H., et al *Physica B* 2006 385-386 1146-1148